

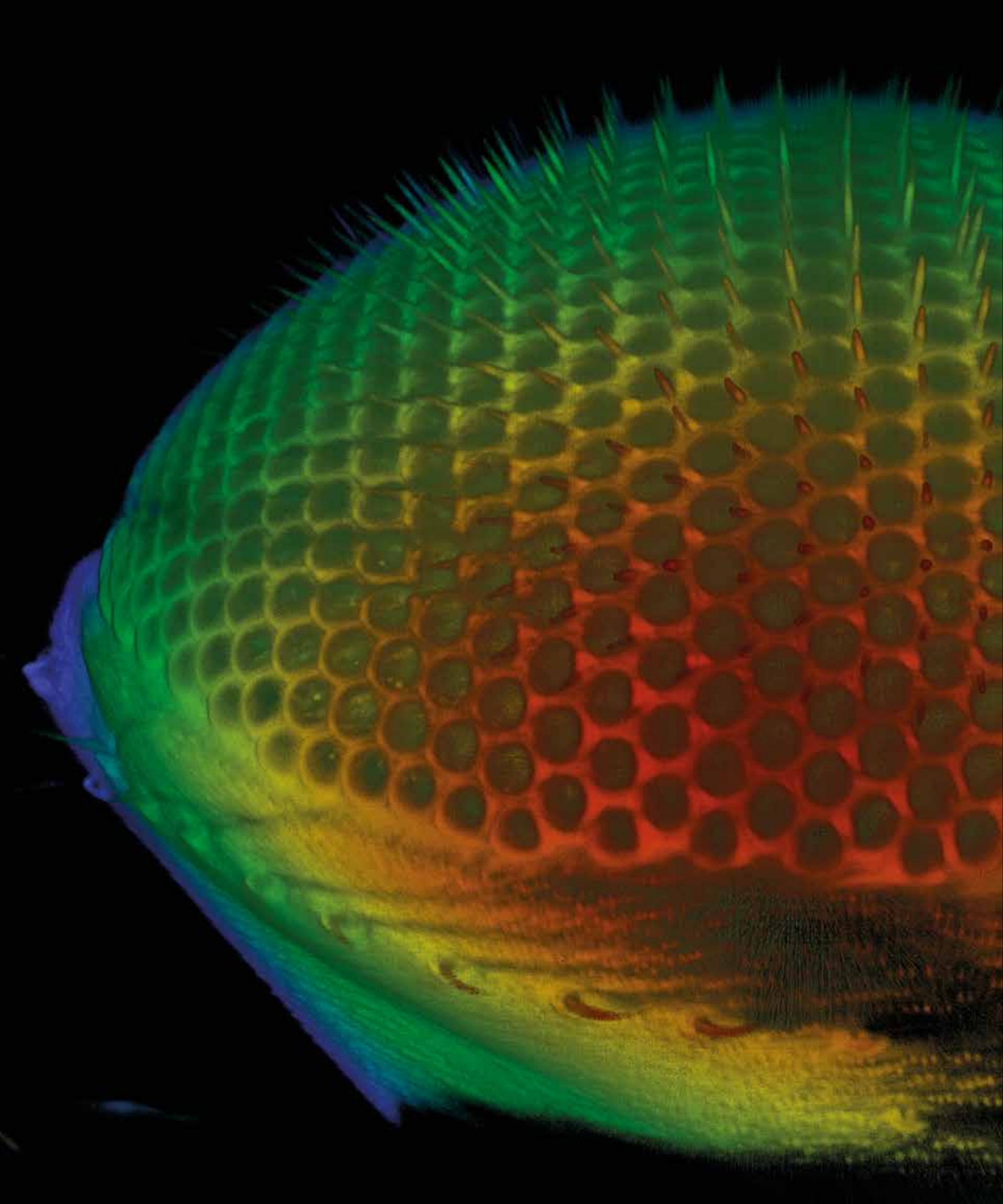

THE
VERTICAL TURN

Leica TCS SP8 DLS
Confocal and Digital LightSheet Microscope



Color coded three-dimensional image of eye specific GFP expression (3P3 promoter) in *Drosophila melanogaster*. Specimen courtesy of Nadja Dinges, Roignant Lab, IMB Mainz, Germany.

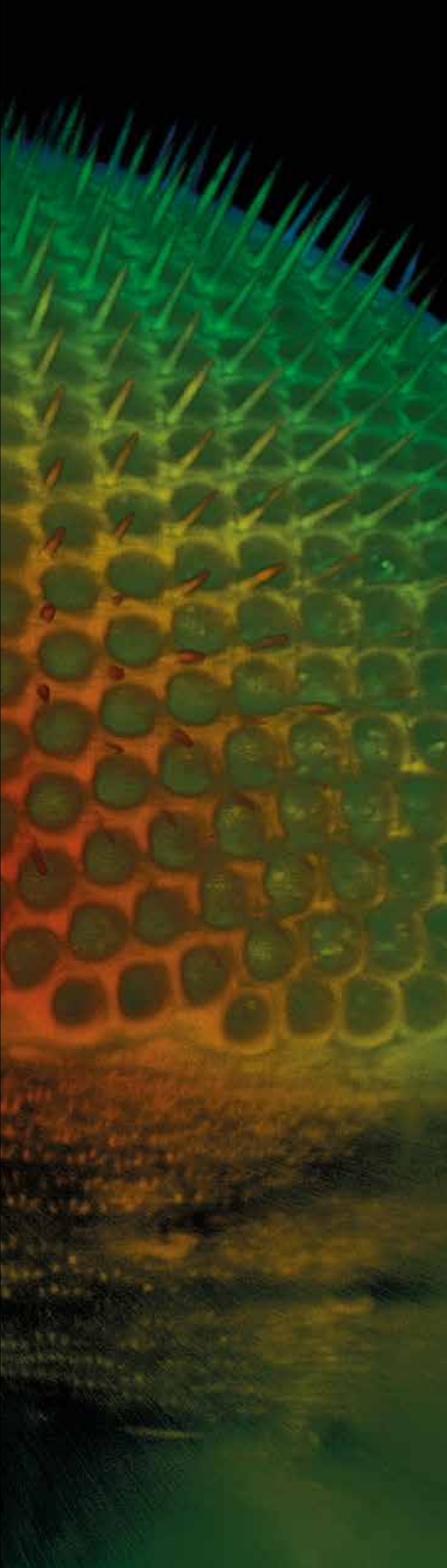

COMBINING LIGHT SHEET AND CONFOCAL – THE LEICA TCS SP8 DLS

Your benefits at a glance:

- > Increase cell viability with single plane illumination
- > Observe fast live processes using an sCMOS-camera
- > Enjoy easy sample handling and multi-position experiments
- > Discover new fields of application by combining confocal methods with light sheet microscopy
- > Illuminate specimens from two sides to overcome darker regions
- > Always find the right imaging method for your application by using the full capabilities of the Leica TCS SP8
- > Turn your confocal into a light sheet instrument:
Upgrade from Leica TCS SP8 to Leica TCS SP8 DLS at any time

Find more
information online



VERTICAL TURN, EXPANDED OPTIONS

Our Leica TCS SP8 DLS combines a complete confocal microscope with gentle single plane illumination in one system. The innovative TwinFlect mirror has turned the Leica TCS SP8 confocal platform into an easy and versatile light sheet microscope. Benefit from THE VERTICAL TURN!

More options for your research

Living specimens – particularly developmental processes in embryos – are often very sensitive to light exposure. Illuminating your sample only in one single plane at a time reduces the light dosage extremely and extends the viability of your cells. With the Leica TCS SP8 DLS, you can discover the dynamics of a living organism over an extended period of time and observe live processes like the heartbeat of a zebrafish embryo by ultrafast image acquisition. Image large specimens in 3D, while keeping the flexibility of your Leica TCS SP8 confocal microscope.

Light sheet on confocal

The synergy of the light sheet module with the confocal microscope offers new options for imaging applications: You can easily combine confocal photomanipulation methods with your light sheet experiment. Use the lasers in confocal mode for photoconversion or wounding experiments and subsequently switch to light sheet mode in the Leica Application Suite (LAS) X software for long-term observations with reduced light dose. The easy and familiar sample handling and the confocal stage automation allow you to observe multiple organisms in one setting.

The innovative TwinFlect technology

Light sheet microscopy usually requires a dedicated optical setup on an independent system, where the illuminating and detecting objective are perpendicular to each other. The Leica TCS SP8 DLS makes lightsheet microscopy easier than ever before. The unique TwinFlect mirror deflects the illuminating light sheet at a 90° angle and allows the integration of the illumination and detection beam path into the vertical axis of every inverted Leica TCS SP8 without compromising confocal functionality. The light sheet arm of the Leica TCS SP8 DLS replaces the regular transmitted light arm of the Leica TCS SP8 with special detection optics, which transfer the fluorescence from your sample to a high-speed sCMOS camera.

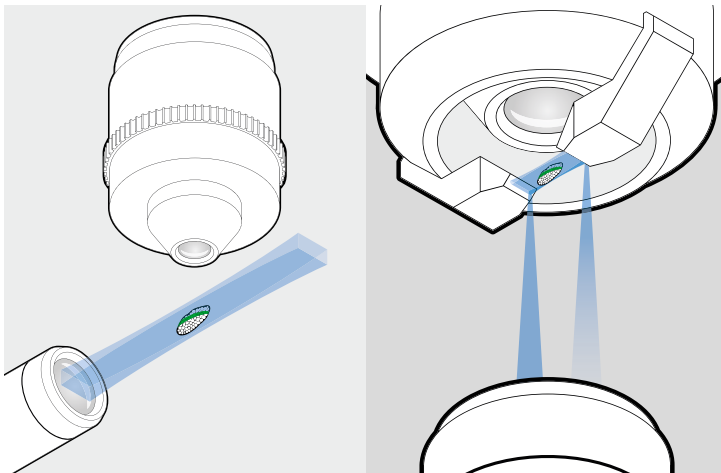

Conventional light sheet set-up vs. Leica TCS SP8 DLS.
The TwinFlect mirror deflects the light sheet at a 90° angle and enables integration of illumination and detection objectives into the vertical axis of an inverted microscope.

A close-up photograph of a Leica DLS microscope. The top part of the image shows the white head of the microscope with the 'LEICA DLS' logo in black. Below the head, the black mechanical structure of the microscope is visible, including the objective turret and the objective lenses. Two objective lenses are shown in the foreground, angled towards the right. The background is a plain, light color.

LEICA DLS

High-end optics for demanding applications

Superior objectives for a wide range of applications is one of Leica Microsystems' hallmarks. The heart of our system turning the light sheet vertically is formed by the objectives and the TwinFlect mirror. With the choice of two different illumination objectives, the Leica HC PL Fluotar 2.5x/0.07 or the Leica HCX PL FLUOTAR 5x/0.15, you can shape the light sheet depending on the experiment's requirements. In order to reveal the finest details or have a larger field of view, you can pick the optimal detection objective, either the Leica HC FLUOTAR L 25x/0.95 W or the Leica HC APO L 10x/0.3 W water immersion objective.

Low phototoxicity and specimen imaging in 3D: Development of *Drosophila melanogaster* over 6 hours. Probe: Light-sensitive RFP. 3D rendering. 150 μm z stack, 30 sec/stack.

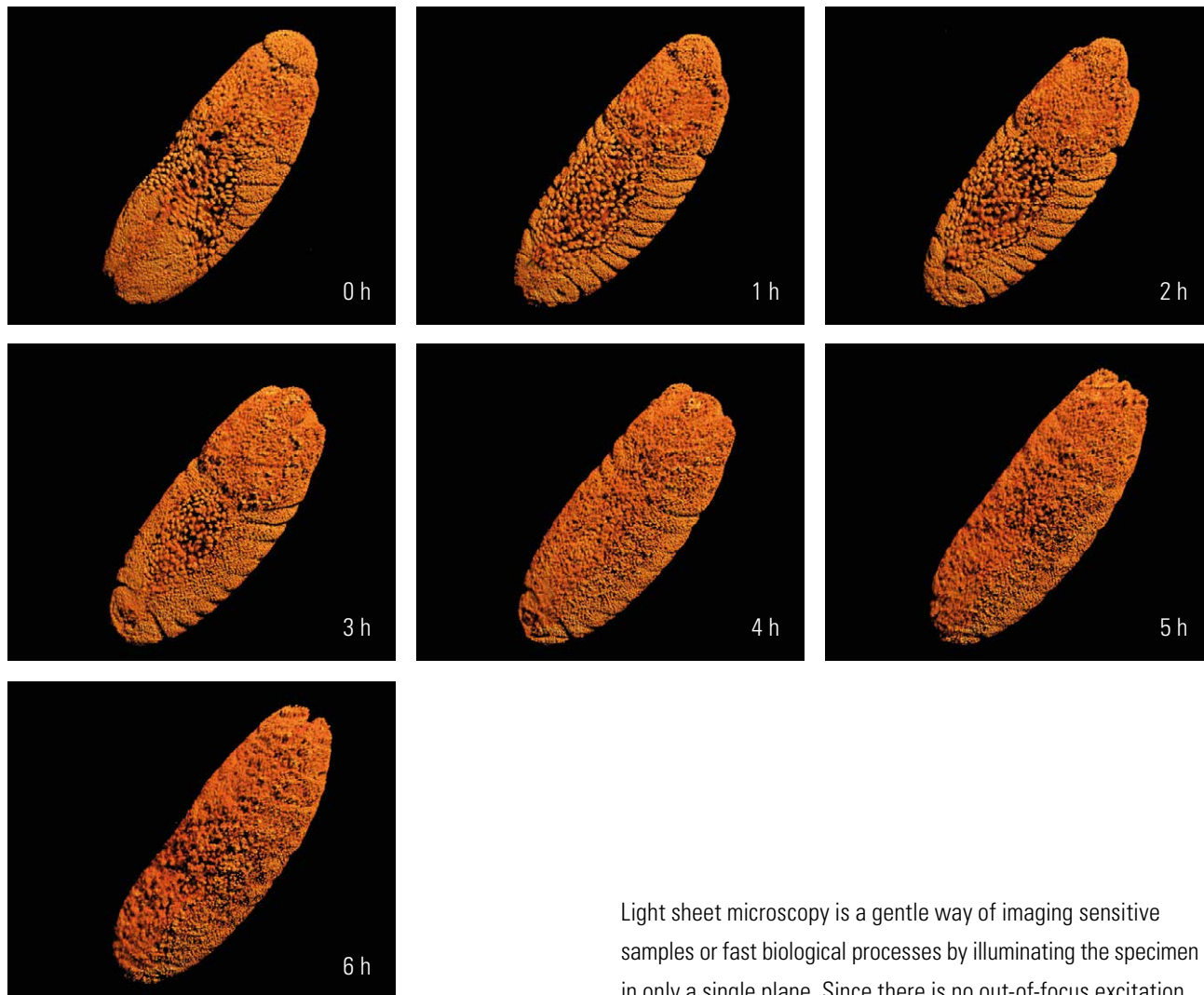

Light sheet microscopy is a gentle way of imaging sensitive samples or fast biological processes by illuminating the specimen in only a single plane. Since there is no out-of-focus excitation, phototoxic effects can be reduced to the focal plane. It also means that you automatically have optical sectioning and you can image specimens in 3D by moving the sample through the light sheet.

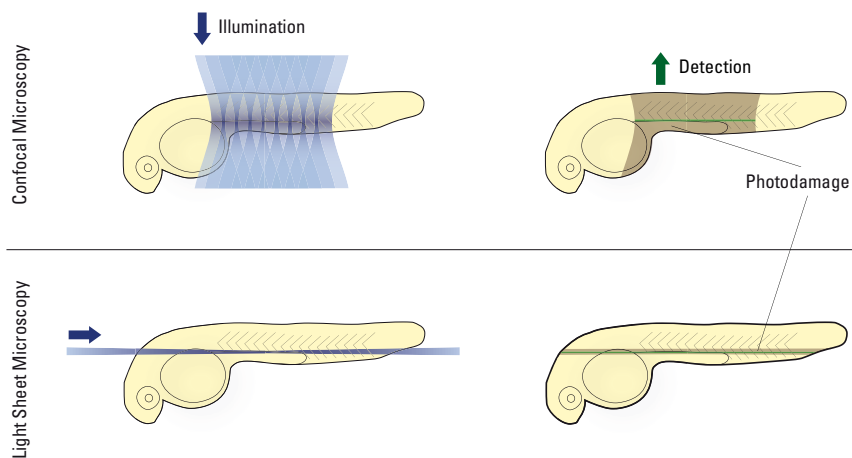

CONDUCT AND DOCUMENT LONG-TERM OBSERVATIONS

Light sheet technology by Leica Microsystems allows you to observe the development of interesting organisms over a longer span of time using low illumination and high speed.

Watching developments in real time and 3D

Imaging requires light, but too much light can damage your cells. Light sheet microscopy is the most gentle imaging method to date, as it reduces the overall photodamage from phototoxicity and bleaching. This automatically increases the viability of your specimen. Particularly researchers in developmental biology benefit from light sheet imaging: The combination of low illumination and high-speed acquisition allows you to follow sensitive developing organisms like a *Drosophila* embryo over long time periods and to understand how tissue and organs form in real time and 3D.

The perfect tool for your gene of interest

Genome editing methods with engineered nucleases like ZFNs (zinc finger nucleases), TALENs (transcription activator-like effector nucleases) or the CRISPR/Cas (Clustered Regularly Interspaced Short Palindromic Repeats/CRISPR associated nucleases) system tag endogenous proteins with fluorescent markers. They generate transgenic organisms with low, but physiologically relevant expression levels of a gene of interest. However, confocal microscopy often bleaches the faint fluorescence of the few molecules quickly. The Leica TCS SP8 DLS is a perfect tool for you to reveal the physiological function of your gene of interest at endogenous expression levels.



FAST IMAGE ACQUISITION WITH EXCELLENT RESOLUTION

Do you want to observe fast and periodic biological processes in three dimensions over an extended time period? Then the DLS module is the right choice. Discover the beauty of a beating zebrafish heart, for example.

Track very fast periodic movements

With the Leica TCS SP8 DLS you can choose between two cutting-edge sCMOS cameras for fast image acquisition with excellent resolution and high frame rates: The pco.edge sCMOS camera and the ORCA-flash 4.0 V2 by Hamamatsu are both fully integrated into the LAS X LightSheet Wizard. A new xyzt scan mode in the LAS X software acquires time series of single planes, which can be fused to a 4D movie afterwards. This allows you to track very fast periodic movements, which are too fast to follow by conventional time-lapse recordings of z-stacks.

xyzt

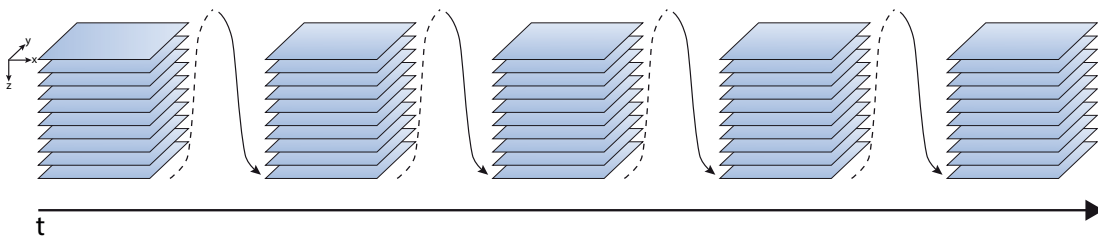

xytz

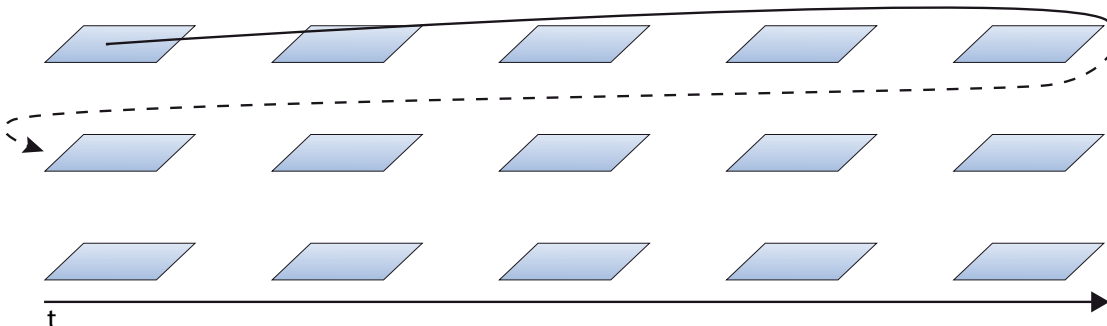

High-speed imaging: Beating zebrafish heart, transgenic line *flik1::EGFP*. Top: transverse section at different time points. Bottom: Post-acquisition alignment after xytz recording. Recording speed: 120 frames/second. Courtesy of Emily Steed, Vermot Lab, IGBMC Strasbourg, France.

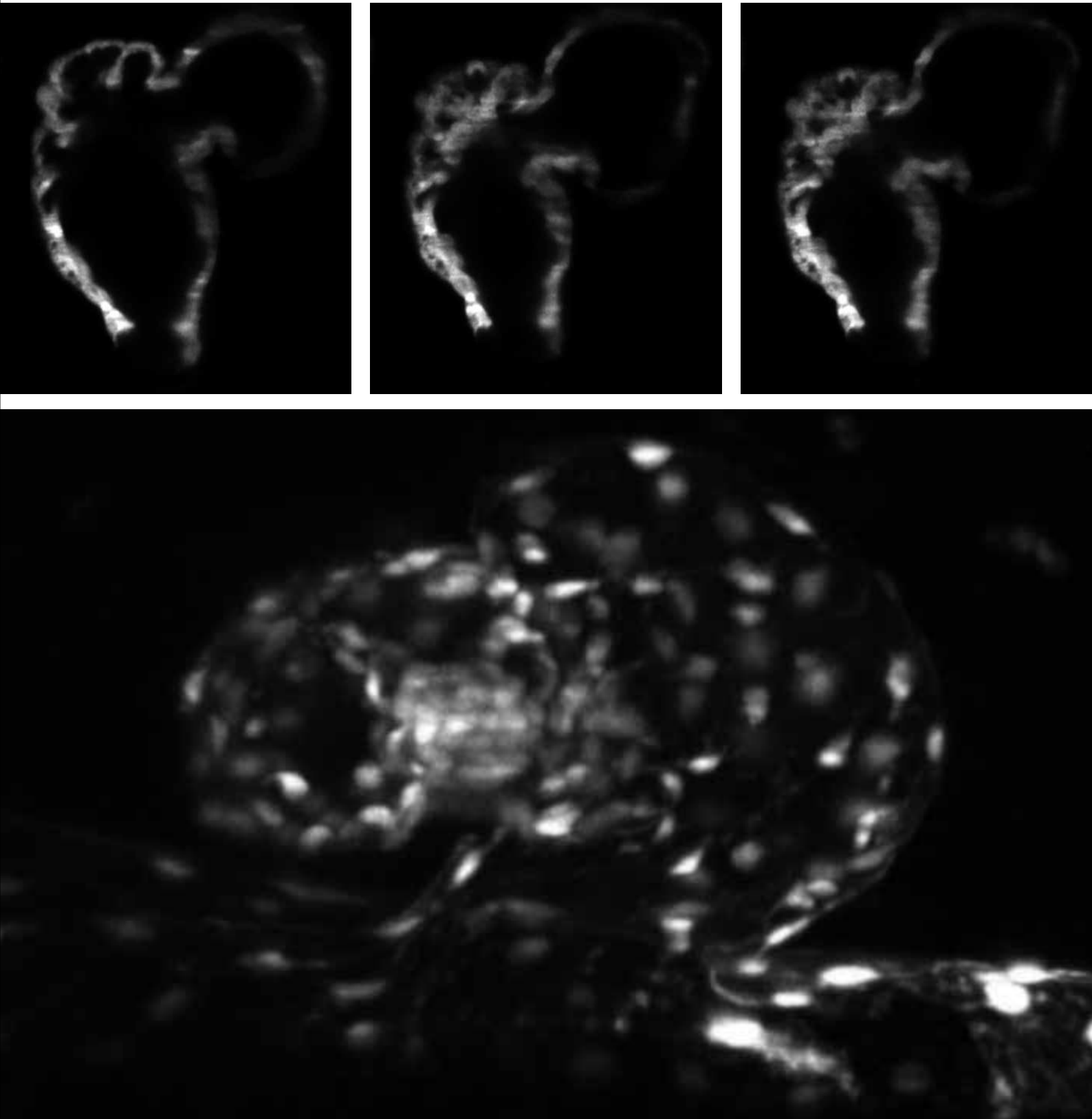

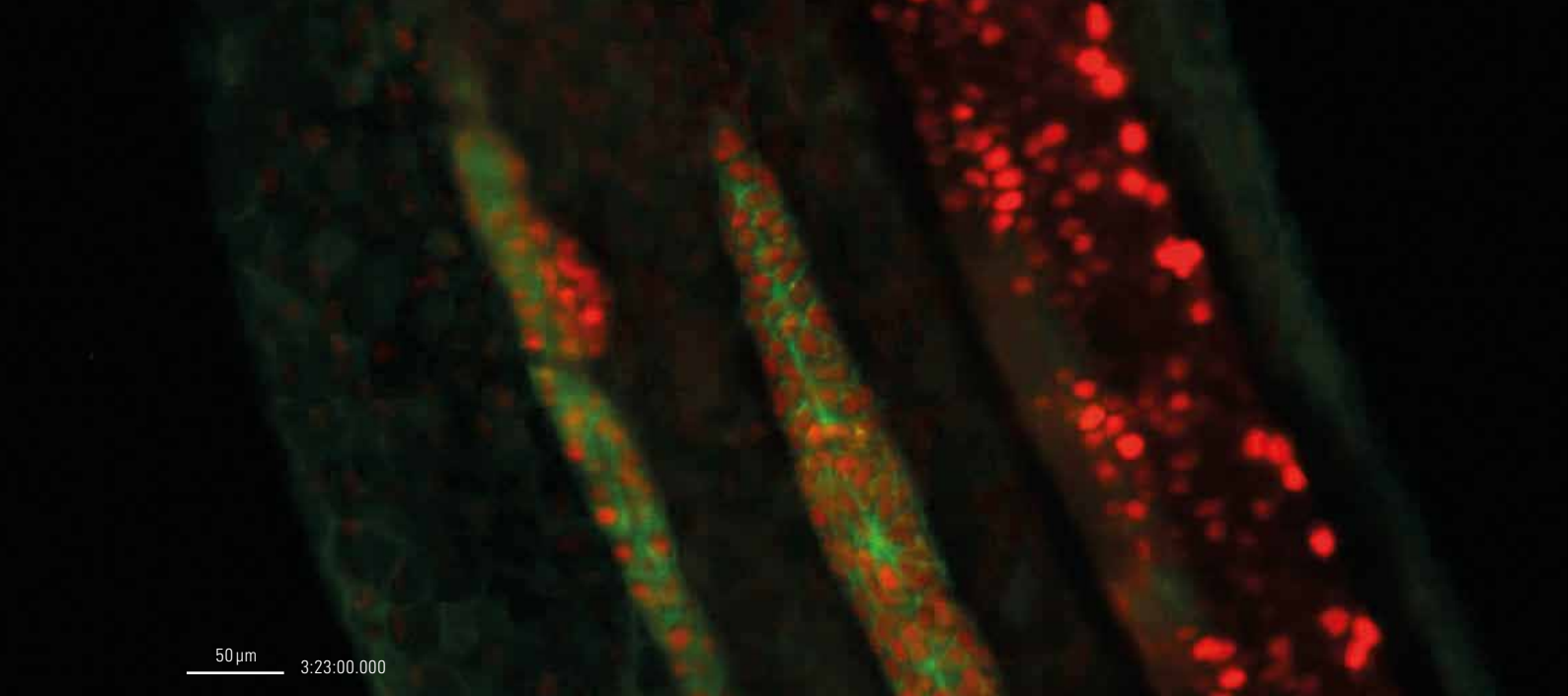

Long-term, multicolor observations: 17 hours of zebrafish lateral line development.
 Zebrafish 36hpf, CldnB:lynGFP / Cxcr4B:nuclearRFP.
 Sample courtesy of Darren Gilmour, EMBL Heidelberg, Germany.

Simply switch between modes

Our LightSheet module is more than a functional add-on to your confocal. The Leica TCS SP8 and Digital LightSheet synergize and give you the possibility to expand your options. You can easily manipulate your specimens using the confocal technology by simply switching between confocal and light sheet mode in LAS X software. Photoconversion or wounding experiments with subsequent gentle long-term observations become easy and convenient.

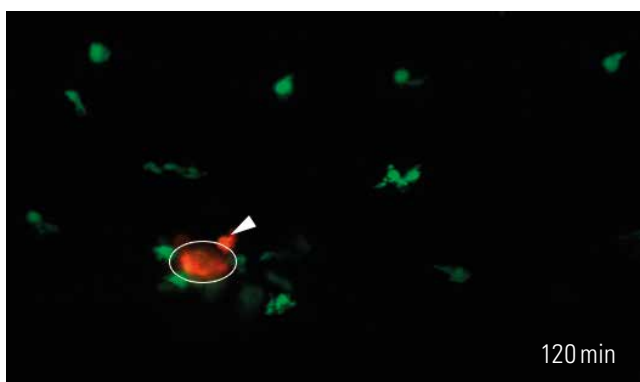
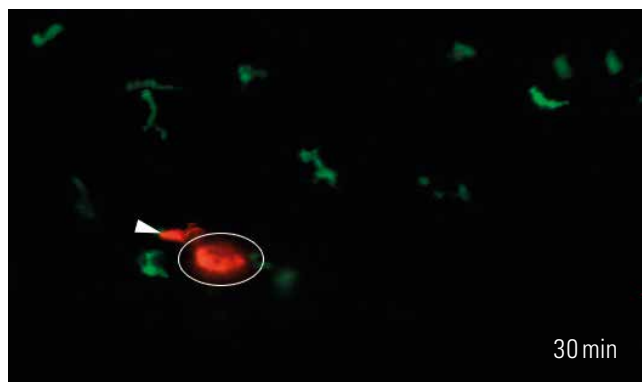
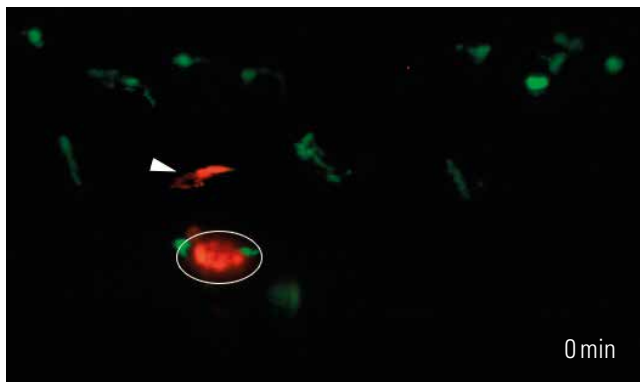

Combining imaging modes: Photoconversion (405 nm laser) and wounding (multiphoton laser) in the tail of a Kaede transgenic zebrafish embryo. Time-lapse recording of photoconverted macrophage cell (arrow head) migrating towards the wound (circle). Right side: Tracking of converted cell using LAS X 3D Analysis.
 Sample courtesy of Francesca Peri, EMBL Heidelberg, Germany.

BENEFIT FROM MANY ADDITIONAL APPLICATIONS

We have added light sheet technology to our confocal platform – you get two high performance microscopes in one.

Always the right laser option

All visible lasers of your Leica TCS SP8 confocal are ready to be used for light sheet imaging. The highest flexibility in choosing the right dye for your light sheet experiment is offered by the white light laser. It even allows you to use spectrally close fluorophores in multicolor experiments.

Familiar sample preparation

Due to the vertical experimental setup of the Leica TCS SP8 DLS, you can stick closely to your routine sample preparation. The specimens are mounted in conventional glass bottom petri dishes and are directly accessible. You even have the possibility of screening several samples in multi-positioning experiments: Making use of the confocal stage automation, several specimens can be imaged in one experimental setup. The only precondition? Space for the TwinFlect mirrors on each side of the sample.

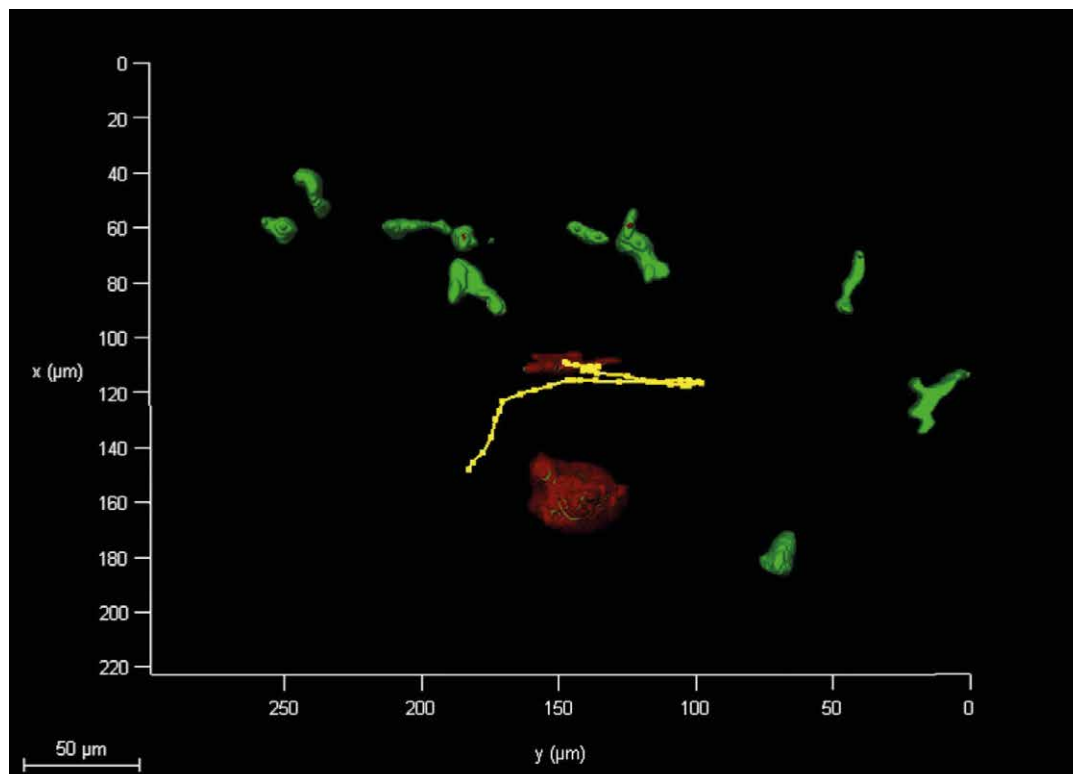

PARTNERS IN SCIENCE – WE FOCUS ON YOUR NEEDS

Time is too precious to spend on complicated experimental set ups.
That is why we focus on intuitive and convenient system design.

Workflow-oriented software design

The LAS X microscope software guides users step by step through data recording and evaluation. The workflow-oriented design helps you to use the instrument more efficiently. A convenient calibration routine establishes the light sheet precisely. Dual-sided illumination of the sample comes by design: Each of the two opposing mirrors of the TwinFlect can be targeted by the scanner to overcome darker areas. For crisp images from a large field of view you can fuse the two images using the online or offline fusion options of the LightSheet Wizard in the LAS X software.

Tailor LAS X to your needs with additional software packages. The LAS X 3D Visualization module provides novel ways to interact with your three-dimensional data with intuitive clipping, fast rendering, and stereo display. Tiling experiments enable you to observe large areas and Mark & Find experiments allow you to observe several regions of interest in a multi-position set up.

Software-controlled climate chamber Convenient data handling

A software-controlled climate chamber keeps the environmental conditions that your specimens like best. Users gain full control of the experimental conditions with the LAS X Environmental Control module. The logged environmental data can be monitored during the experiment. All environmental conditions can be set within one interface, and you can run temperature profiles, for example, for heat shock experiments.

Observing processes in 3D and over long time periods generates a lot of data. Several tools implemented into the LAS X software help you to manage your data conveniently. The online fusion tool gives you the choice to keep raw data or to save disc space with only the fused image. Your data is automatically saved during acquisition, and the smart loading facilitates data review by giving you direct access to the time points or z stacks of interest in large time-lapse data sets. You can compile your desired post-processing steps in a pipeline, which is automatically processed.

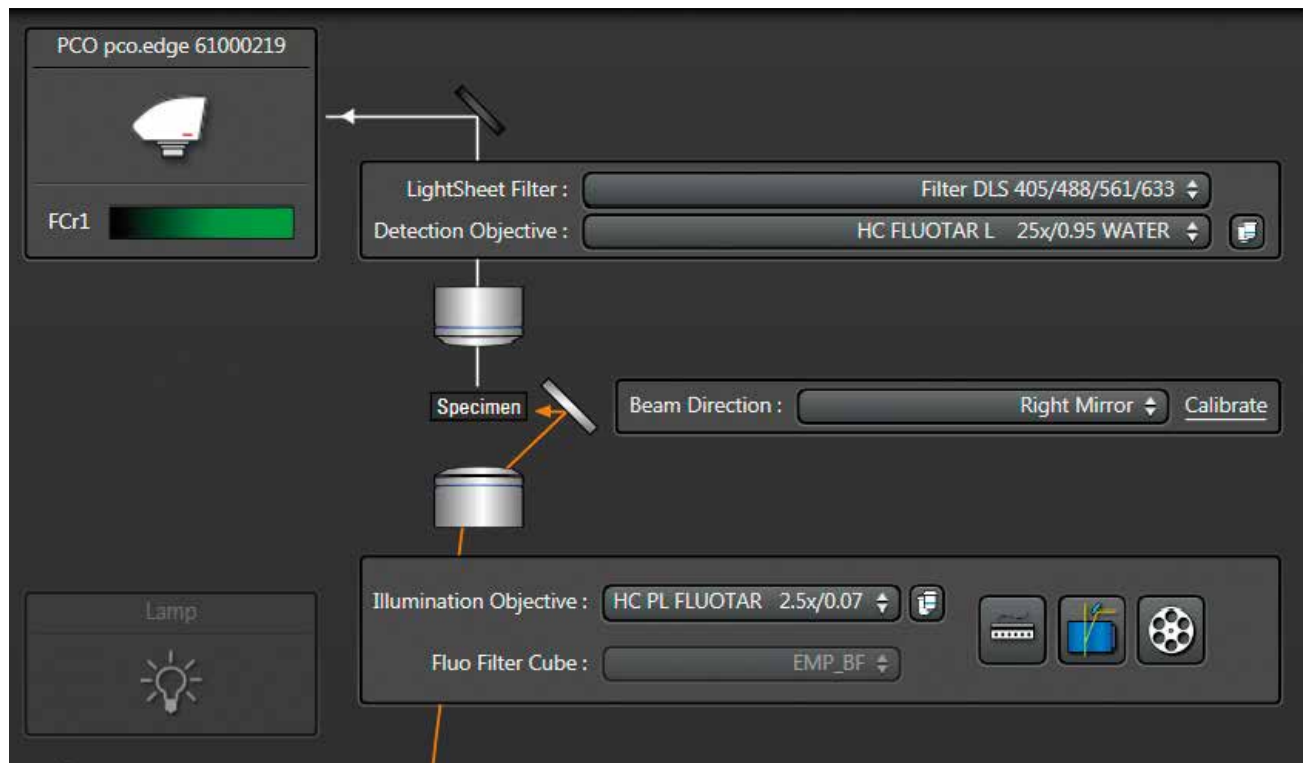
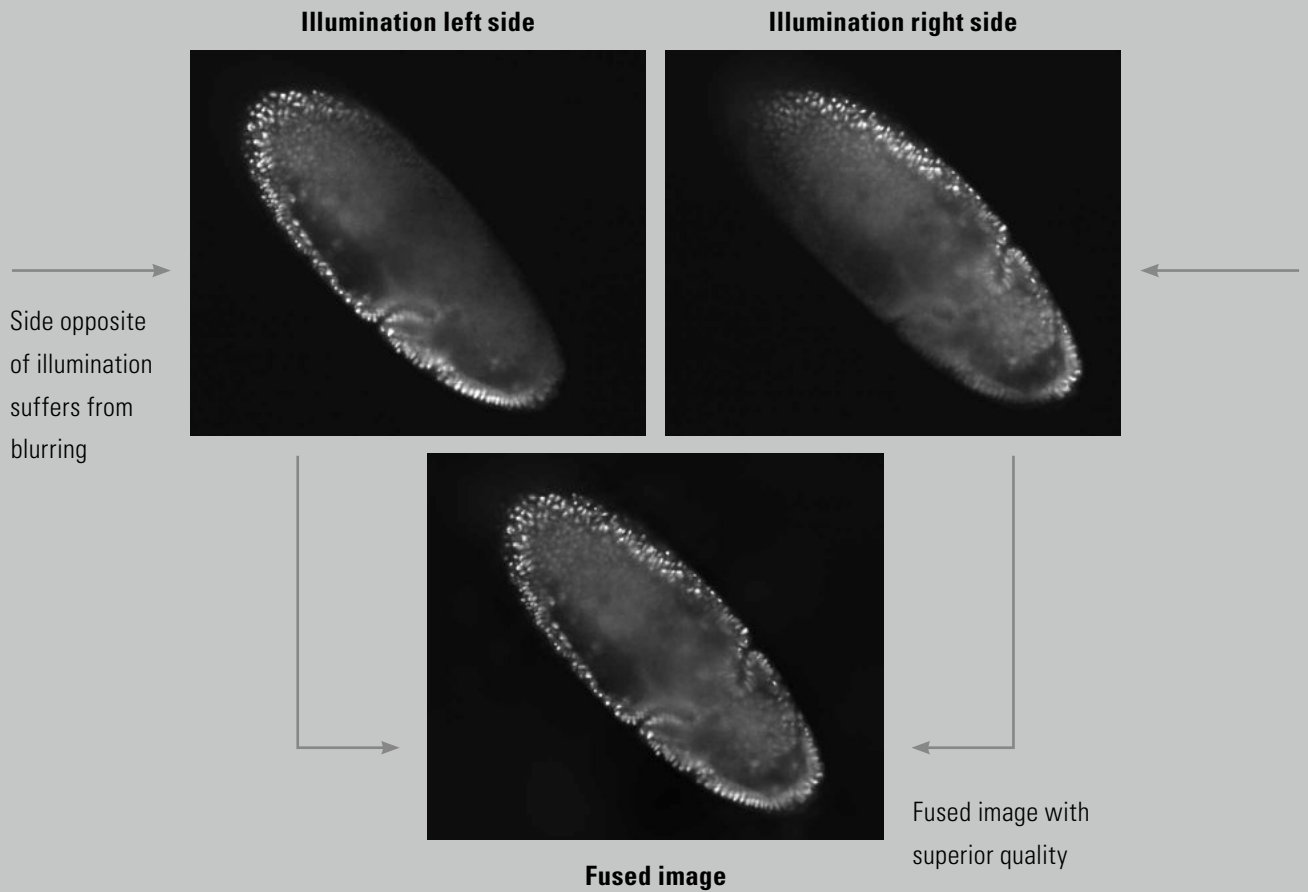

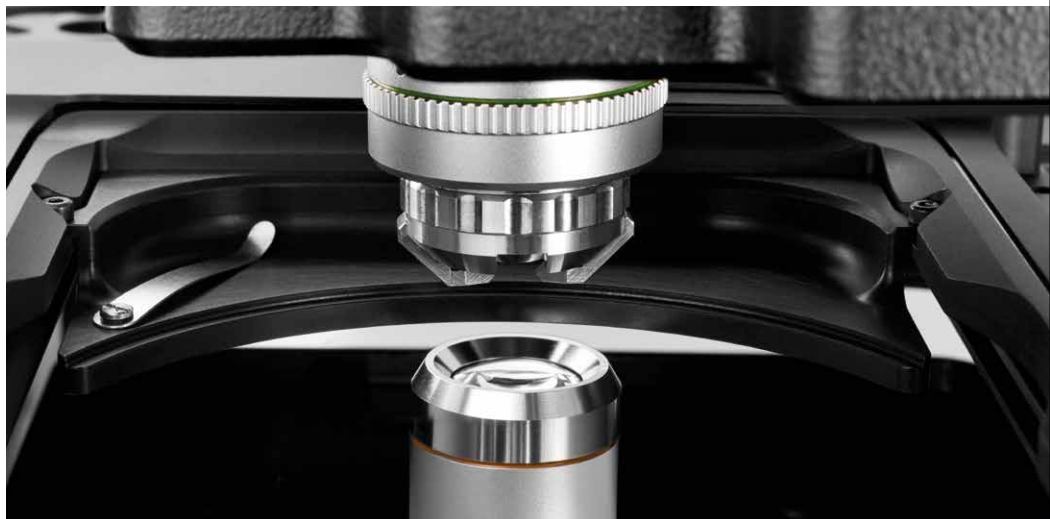
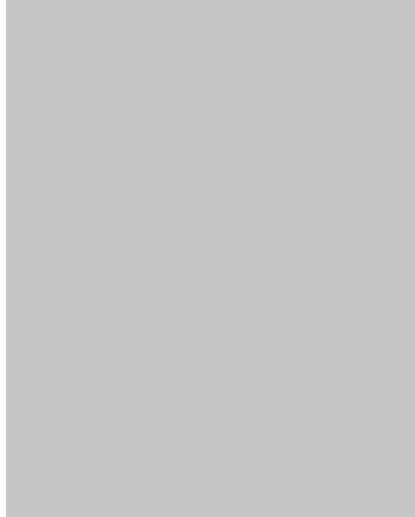

LEICA TCS SP8 – THE PLATFORM THAT KEEPS UP WITH YOUR SCIENCE

Which direction will your research go in the future? The Leica TCS SP8 confocal platform was designed with upgradability in mind. Discover the whole microscopy world – from super-sensitivity to super-resolution, from multiphoton to light sheet imaging – in one system.

Upgrade easily any time!

We build on a modular concept. No matter where you start, you can configure more functionality as your needs evolve. Tailor your microscope to your needs now and upgrade your system any time: Acquire additional detectors and excitation lasers or even advanced imaging modules like STED super-resolution or single molecule detection and high content screening automation.

You will always get the perfect imaging method for your application. The Leica TCS SP8 is a sound investment for your current and future research.

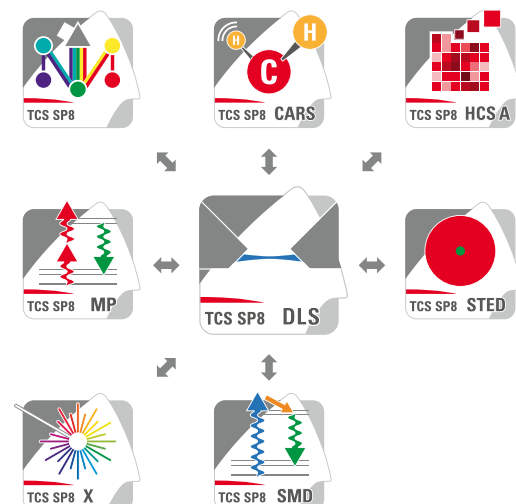



Order no.: English 1593003014 - IV/15 - Copyright © by Leica Microsystems CMS GmbH, Mannheim, Germany.
Subject to modifications. LEICA and the Leica Logo are registered trademarks of Leica Microsystems IR GmbH.
TwinFlect is a registered trademark of Leica Microsystems

www.leica-microsystems.com

CONNECT
WITH US!

